

General Product Documentation

KAPPA VSD

Contents

1	Labels.....	- 3 -
1.1	Compressor Label.....	- 3 -
1.2	Label for Electronic Driver.....	- 4 -
1.3	Electronic Driver Coding description.....	- 5 -
2	Approvals and Certificate References.....	- 5 -
3	Delivery Conditions.....	- 5 -
4	Application Conditions.....	- 6 -
4.1	Oil transport of the compressor in the refrigeration circuit	- 6 -
4.2	Control Modes.....	- 6 -
4.2.1	Autologic Mode.....	- 6 -
4.2.2	Slave Mode (Frequency Control).....	- 6 -
4.3	Protection Features.....	- 7 -
4.4	External Connections.....	- 7 -
4.4.1	Autologic Connection.....	- 8 -
4.4.2	Frequency Control Connection.....	- 9 -
4.5	Diagnostic LED (Optional).....	- 10 -
5	Drawings.....	- 11 -
5.1	Outline Dimensions with short Service Tube.....	- 11 -
5.2	Outline Dimensions with long Service Tube.....	- 13 -
5.3	Outline dimensions with Electronic board, evaporation tray.....	- 14 -
5.4	Evaporation Tray.....	- 15 -
5.4.1	Dimensions of Evaporation Tray.....	- 15 -
5.4.2	Outline Dimensions with Evaporation Tray.....	- 15 -
6	Transport, Packaging, Palletization.....	- 16 -
6.1	Recommended Transport Positions when fitted into Appliances.....	- 16 -
6.2	Packaging and Palletization.....	- 17 -
6.2.1	Packaging Type, Pallet Data.....	- 17 -
6.2.2	Transport.....	- 17 -
6.2.3	Warehouse Storing.....	- 18 -
6.2.4	Recycling of compressors.....	- 18 -
7	Electrical Components.....	- 19 -
7.1	Electronic Driver Assembly.....	- 19 -
7.2	Dismounting of connector for frequency control.....	- 21 -
8	Mounting Accessories.....	- 22 -
8.1	Standard.....	- 22 -
8.2	Optional.....	- 22 -

1 Labels

1.1 Compressor Label

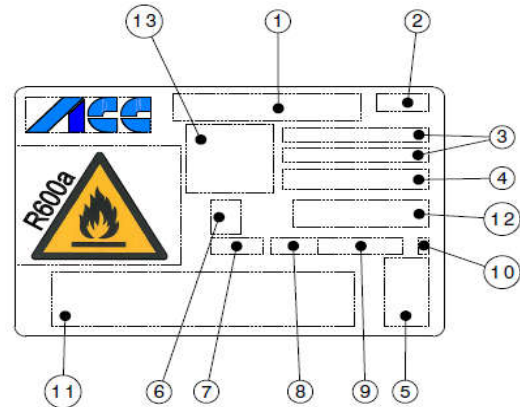

Legend	
1	Compressor model
2	Production date (2 digits year / 2 digits week)
3	Safety warning
4	Electronic driver type
5	Approval marks (VDE and/or CE)
6	Variant code
7	Nickname (4 digits: first digit Platform + version code)
8	Production date (1 digit year / 2 digits week)
9	Serial number (6 digits)
10	Check digit (bar-code)
11	Bar code (14 digits: Platform, version code, serial number and check digit)
12	Suction tube indication
13	Warning symbol

1.2 Label for Electronic Driver

The electronic driver is identified by specific label:

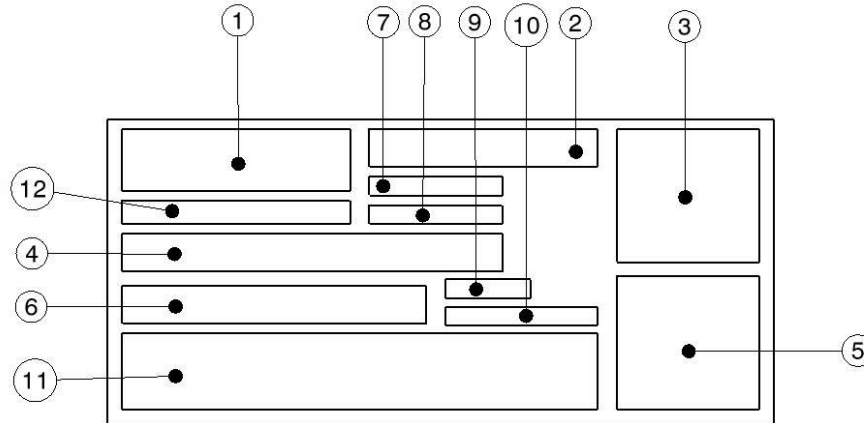

LEGEND	
1	ACC TRADE MARK
2	MANUFACTURER
3	APPROVAL MARKS
4	ELECTRICAL DATA AND TEMPERATURE CLASS
5	DATA MATRIX
6	ELECTRONIC BOARD TYPE (SEE CODING SPECIFICATION)
7	ACC ORACLE CODE
8	SUPPLIER CODE
9	DATE CODE [WW/YY]
10	SERIAL NUMBER [S/N_XXXXXXX]
11	BAR CODE
12	CUSTOMER CODE

Example:



1.3 Electronic Driver Coding description

The code consists of 7 groups as below described:

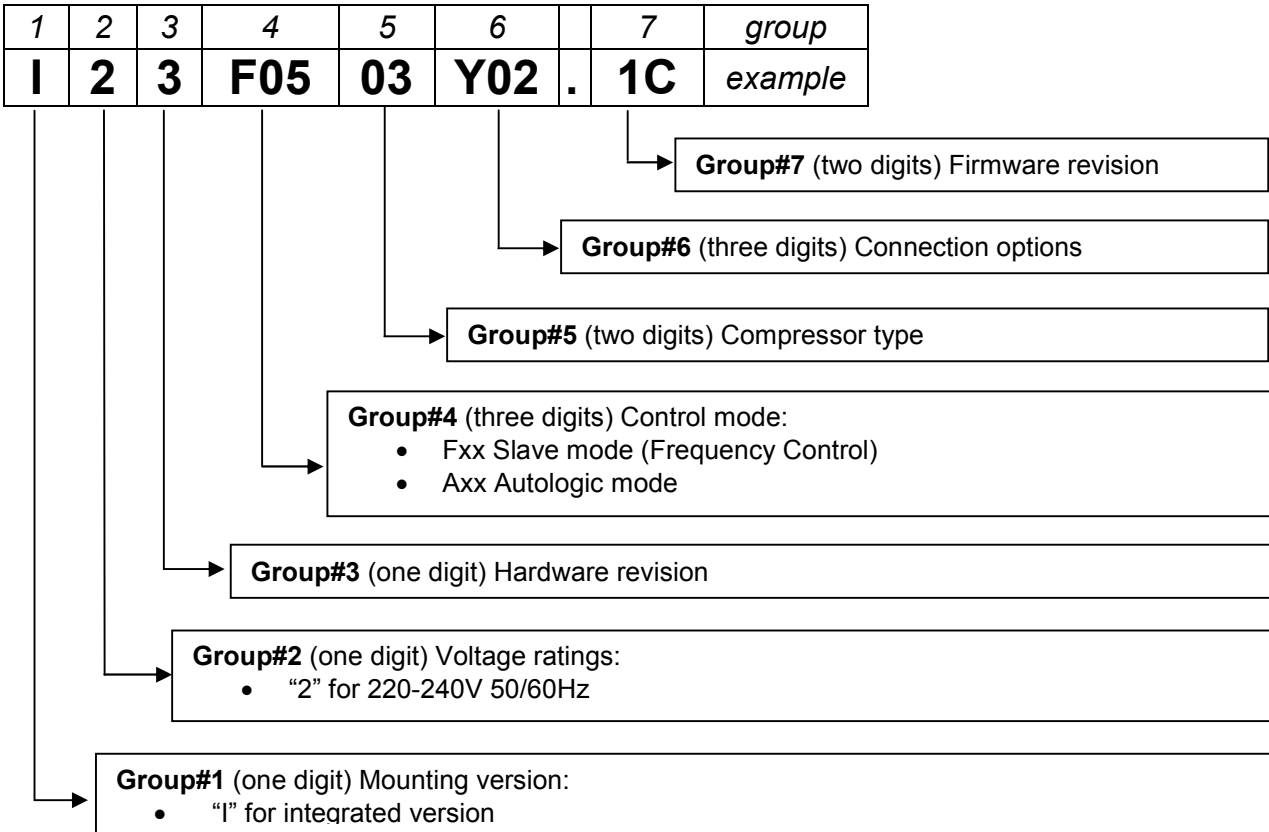

2 Approvals and Certificate References

Model	VDE, (CE) Licence No.
HKK_VSD	40033252

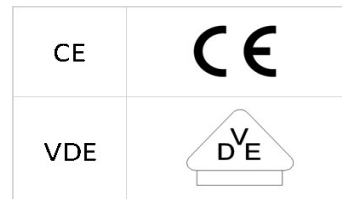

3 Delivery Conditions

Max Solid impurities	[mg]	30
Max Soluble impurities	[mg]	600
Max Total compressor water content	[mg]	100

4 Application Conditions

Max Ambient temp.¹	[°C]	43
Max Steady discharge temp.²	[°C]	120
Max Peak discharge temp.^{2, 5}	[°C]	135
Max Steady condensing temp.³	[°C]	60
Max Peak condensing temp.^{3, 5}	[°C]	70
Max Winding temp.⁴	[°C]	130

¹...static

²...measured on discharge tube, 50 mm from the shell

³...measured in the middle of condenser

⁴...calculated out of the measured difference of resistance

⁵...max 5% of lifetime

4.1 Oil transport of the compressor in the refrigeration circuit

Average value of the transported oil in the refrigeration circuit:

Model	Oil flow rate
	average (g/h)
95	3
70	1,5

4.2 Control Modes

The electronic driver may operate in two different modes:

4.2.1 Autologic Mode

The autologic algorithm determines the best working speed between 1400rpm to 4000rpm according to a logic based on the load cycle of the thermostat

4.2.2 Slave Mode (Frequency Control)

In Slave Mode (Frequency Control) the working speed between 1400rpm to 4000rpm is controlled by a custom electronic board driven by an analogical frequency input signal.

4.3 Protection Features

The following protection features are integrated in the driver.

- Overload and locked rotor protection
 - Restart after 5 minutes
- Motor speed protection:
 - If motor speed falls 200rpm below minimum speed, compressor stops
 - Restart after 5 minutes
- Voltage protection:
 - Shut down of compressor in case of voltage supply out of limits to avoid malfunction.
 - Restart after 5 minutes
- Power Limitation:
 - Protection when input power exceeds 250W within first 5 minutes after starting, and 175W afterwards
 - PWM when current exceeds 6.5A peak
 - Restart after 5 minutes

Some of the listed protection features are safety relevant for the compressor; in this case the compliance to IEC 60335-1 is based on PEC circuit supervised by class B software. The safety of this system can only be guaranteed when the correct driver is used which is indicated on the compressor label.

4.4 External Connections

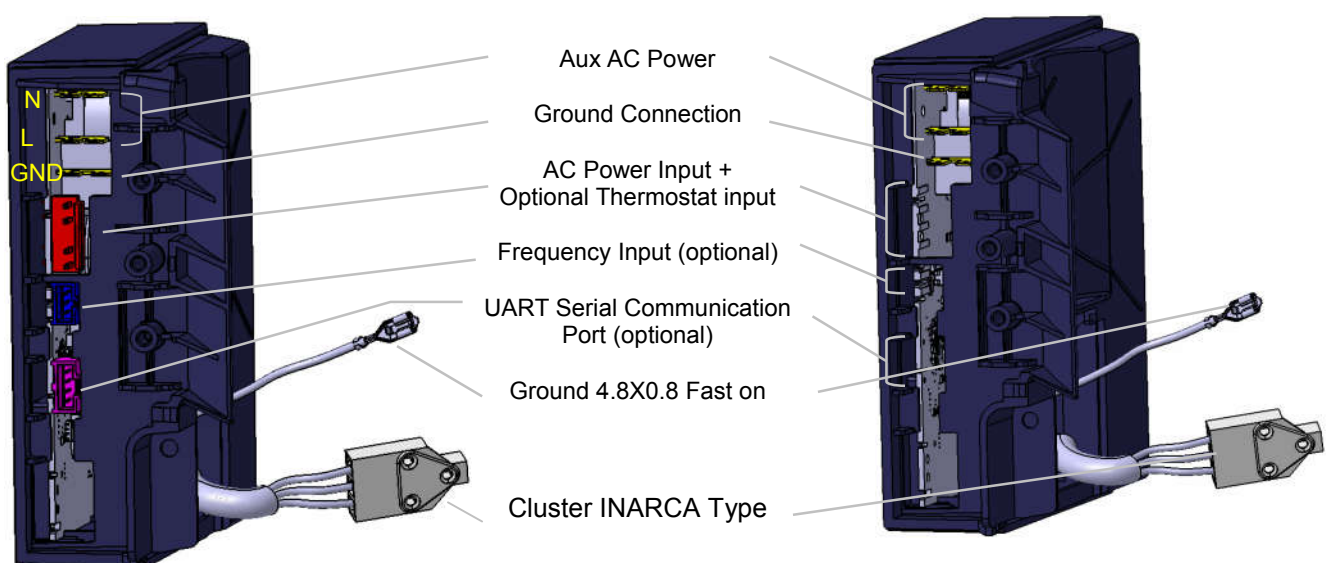

4.4.1 Autologic Connection

Basic connections for autologic are: Line, Neutral and Ground plus a signal coming from thermostat. Dashed connections are intended to be optional.

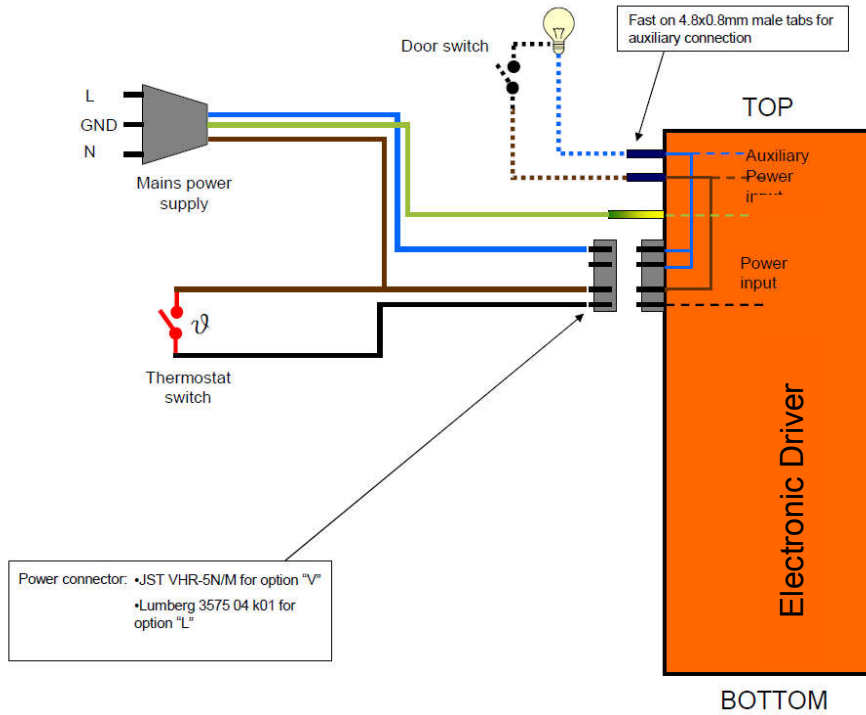

Autologic connection example #1

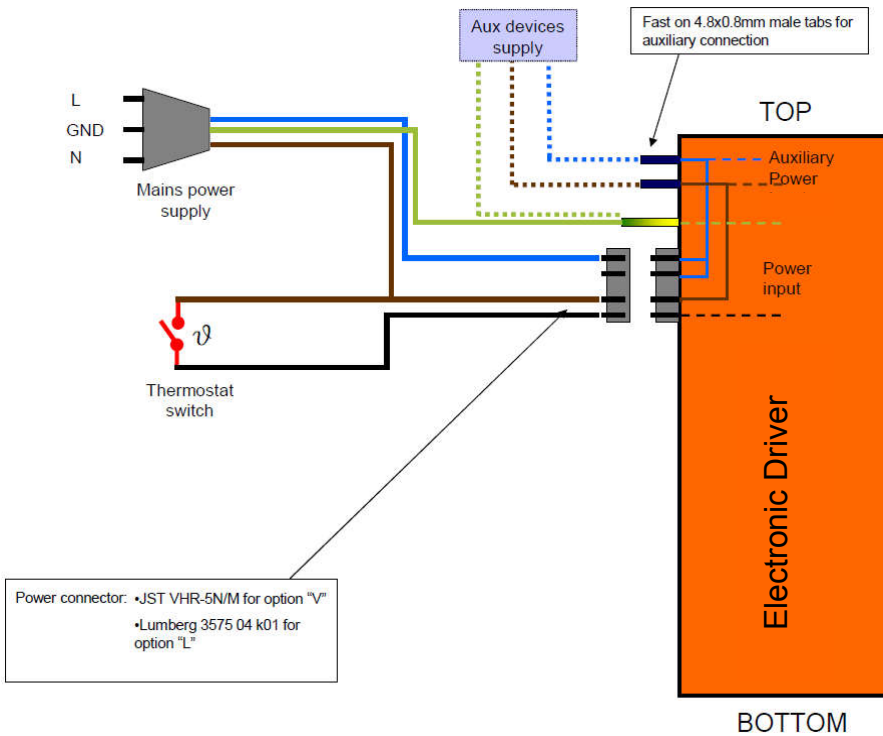

Autologic connection example #2

4.4.2 Frequency Control Connection

Dashed connections are intended to be optional.

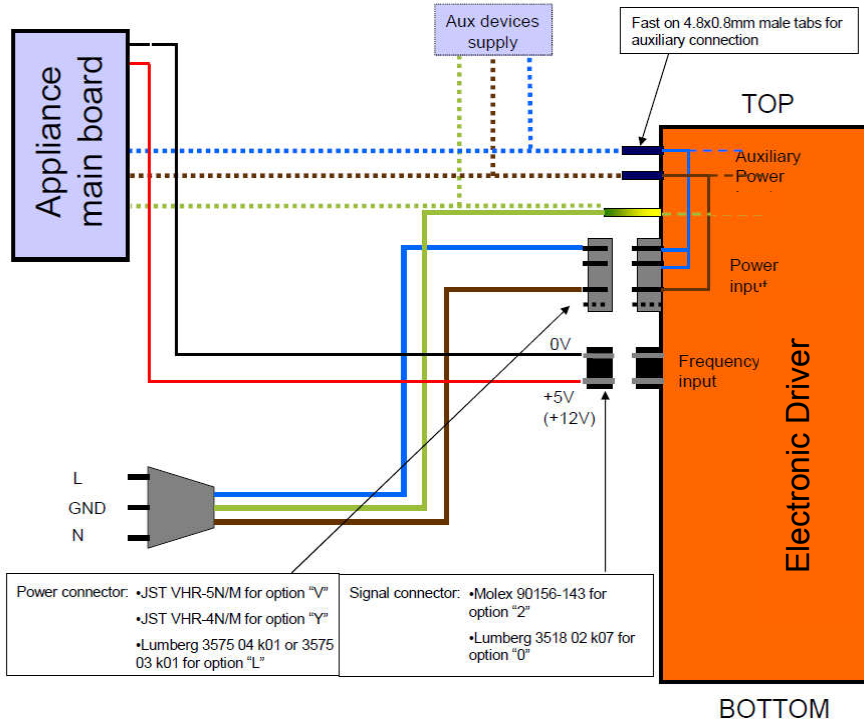

Frequency control connection example #1

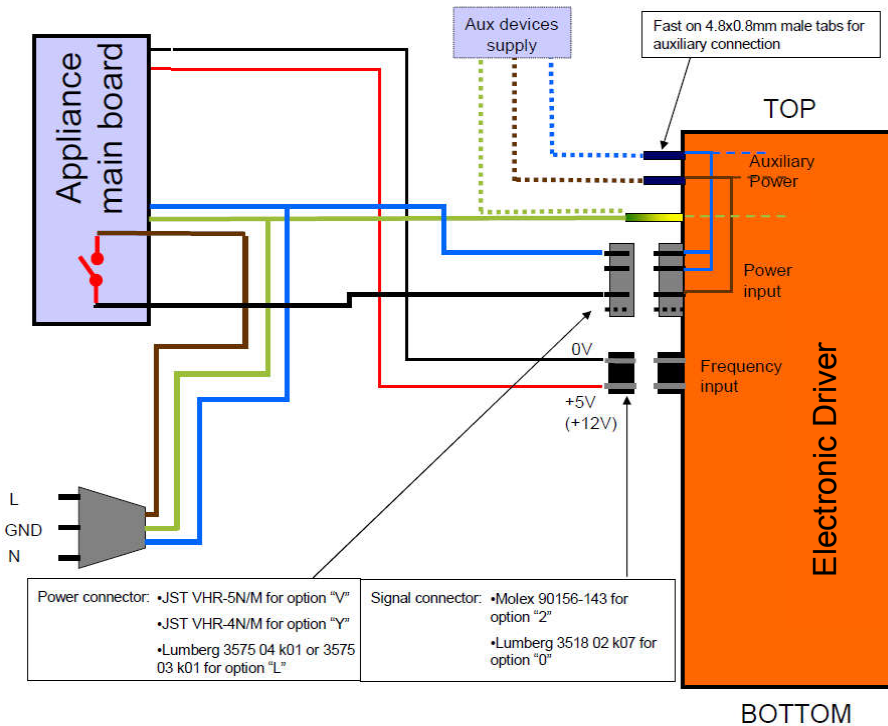

Frequency control connection example #2

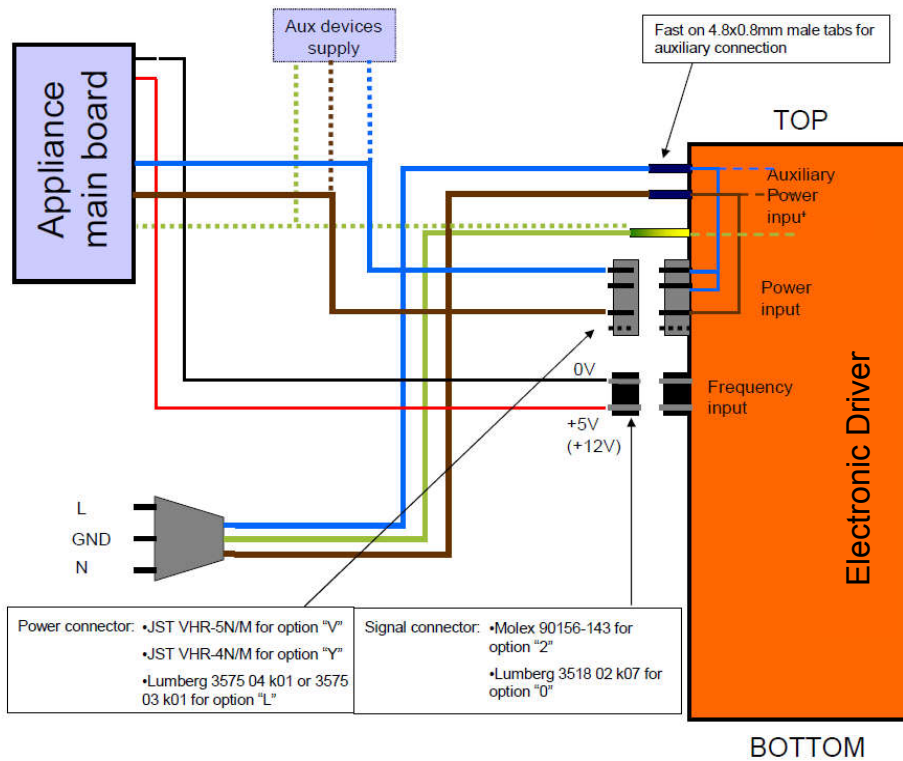

Frequency control connection example #3

4.5 Diagnostic LED (Optional)

This diagnostic-LED indicates a failure on system components. The red LED is positioned on the main PCB on connector side. It is directly visible when a transparent cover is used. Standard cover has to be removed to see the LED.

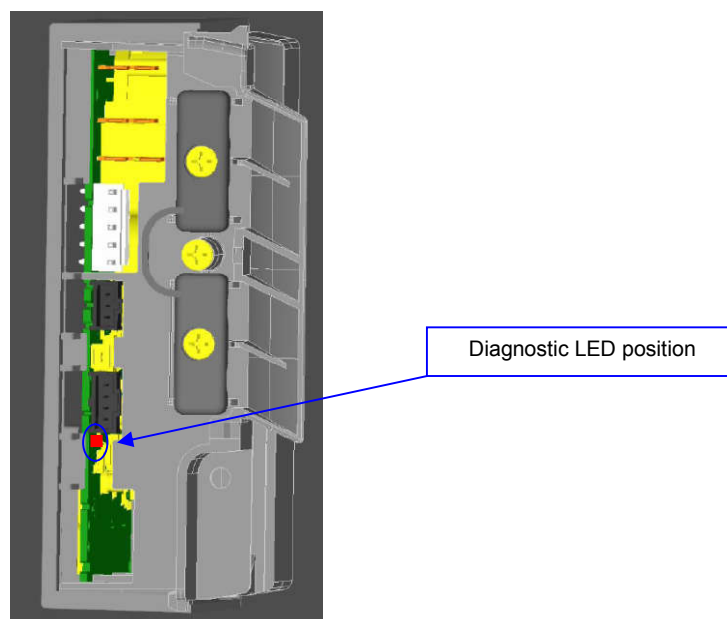

5 Drawings

5.1 Outline Dimensions with Short Service Tube

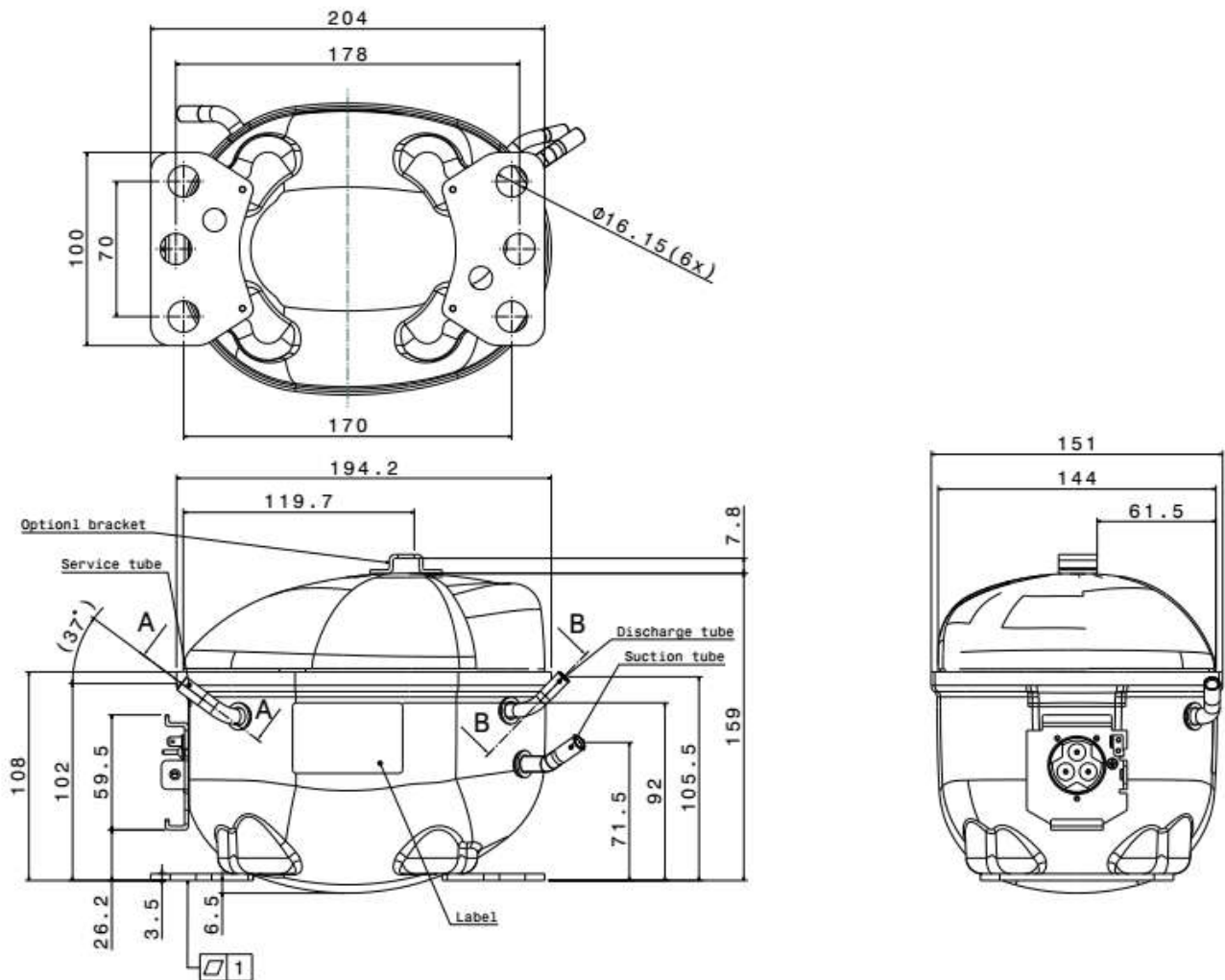

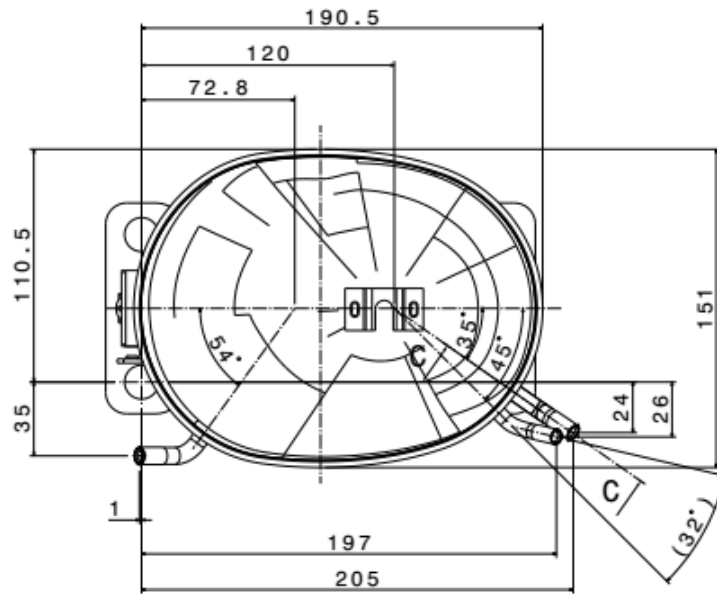

Section C-C
Suction tube

Section A-A
Service tube

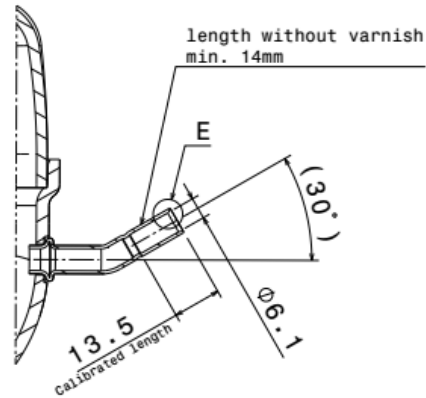
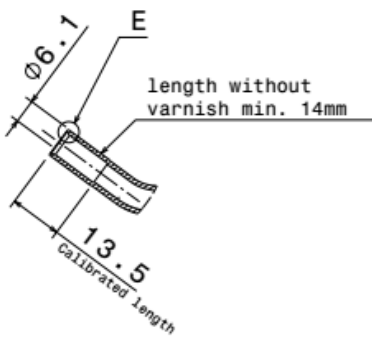

Section B-B
Discharge tube

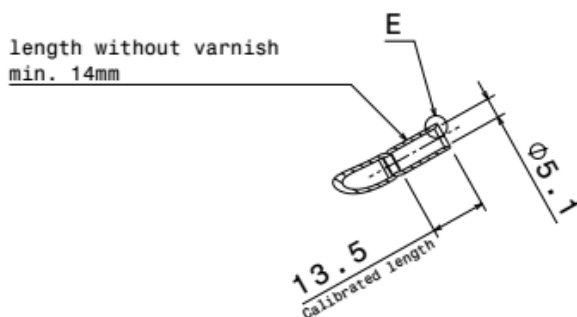

Detail E
Scale 5:1

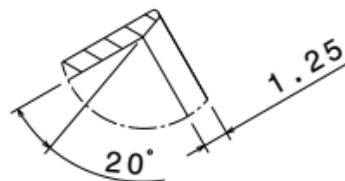

5.2 Outline Dimensions with long Service Tube

All other dimensions and descriptions see Outline Dimensions with Short Service Tube

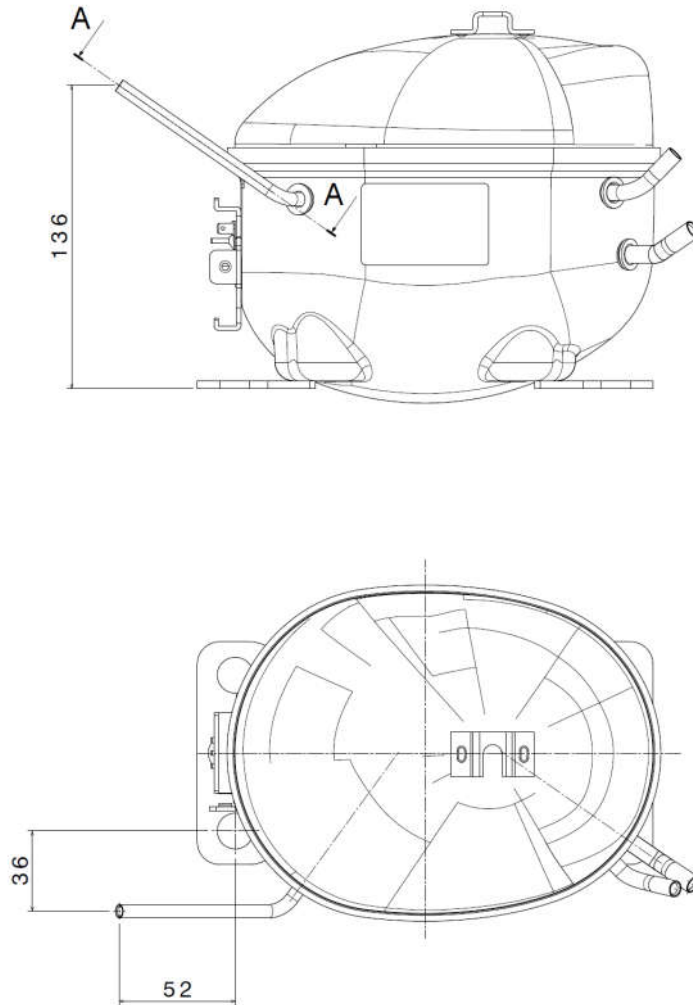

Section A-A
Service tube

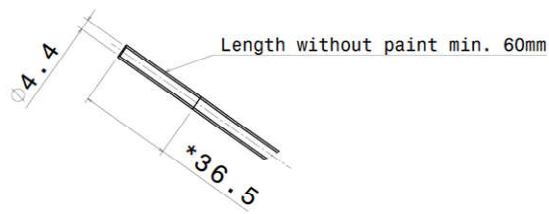

* calibrated length

5.3 Outline dimensions with Electronic board, evaporation tray

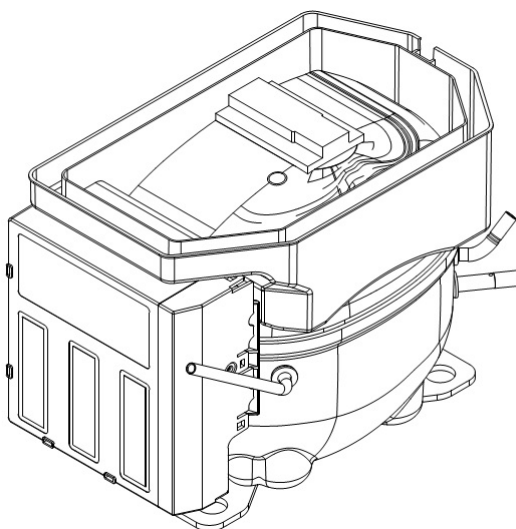
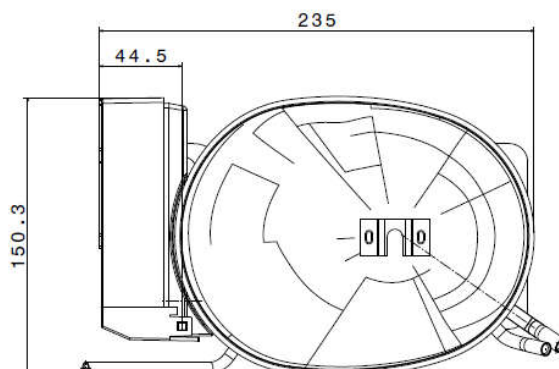
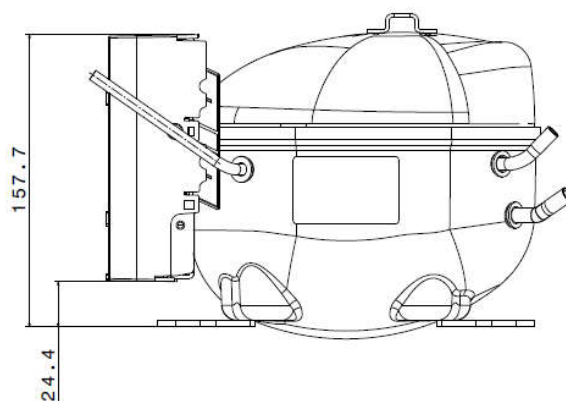

5.4 Evaporation Tray

5.4.1 Dimension of Evaporation Tray

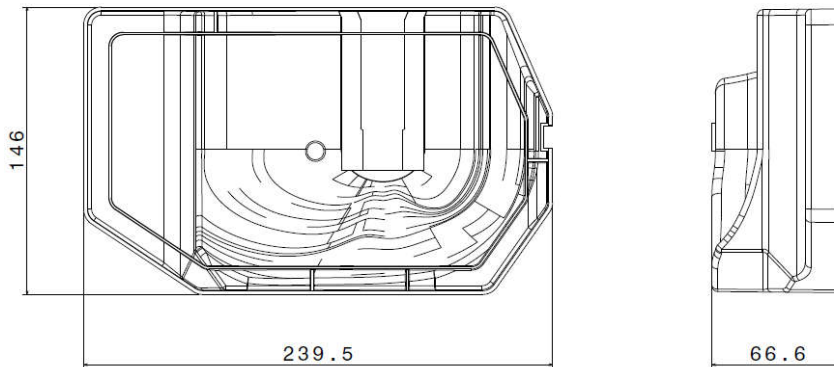

5.4.2 Outline Dimensions with Evaporation Tray

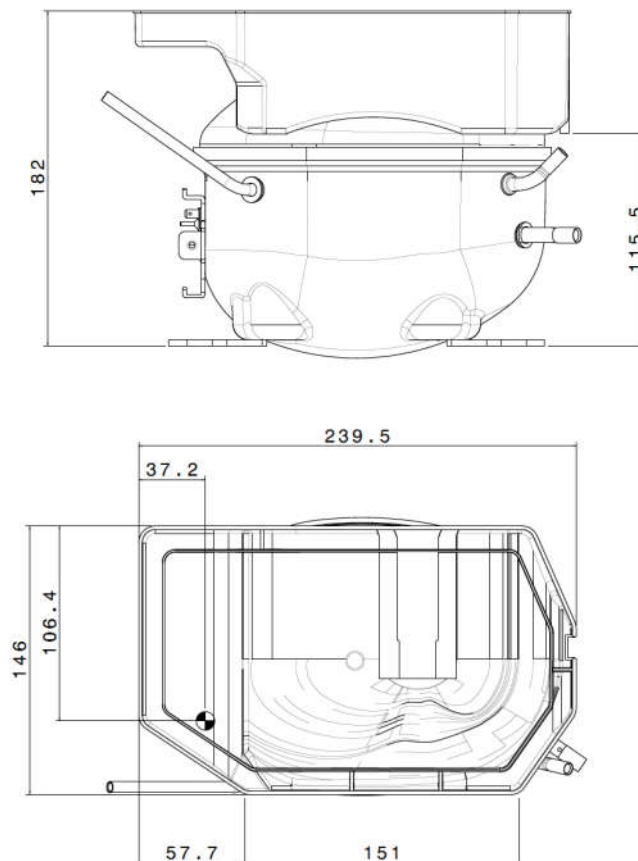

6 Transport, Packaging, Palletization

6.1 Recommended Transport Positions when fitted into Appliances

Upright

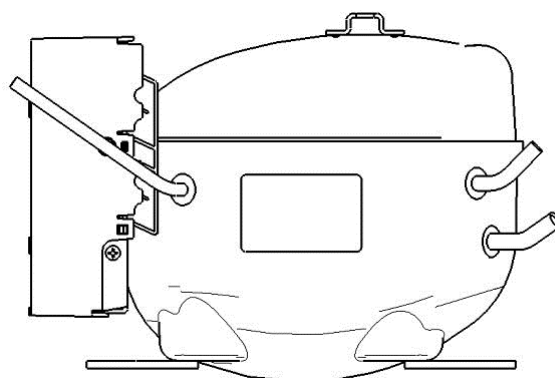

Tubes Down

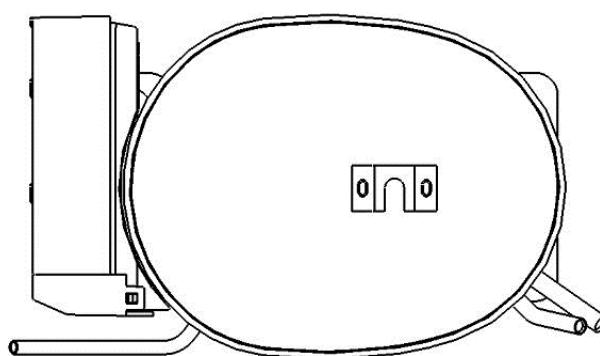

6.2 Packaging and Palletization

6.2.1 Packaging Type, Pallet Data

Packaging-type		Layers	Quantity	Compressors per layer	Pallet Size L x W
				L x W [pcs]	[mm]
One-Way Packaging	Wood-EPS* Packaging	4	80	5 x 4 = 20	1120 x 820
		5	100	5 x 4 = 20	1120 x 820
	Single Packaging	5	60	4 x 3 = 12	1120 x 820
More-Way Packaging	ABS	4	84	7 x 3 = 21	1200 x 800
		5	105	7 x 3 = 21	1200 x 800

*Optional protection and reinforcement with Cardboard-Box and PE Top Foil.

6.2.2 Transport

Packaging-type		Layers	Stacking height Number of Pallets	
			Truck	Container
One-Way Packaging	Wood-EPS Packaging	4	1	-
		5	1	-
	Wood-EPS + Cardboard-Box	4	1	-
		5	1	-
	Wood-EPS + Cardboard-Box + PE Top Foil	4	1	2
		5	1	2
Single Packaging	5	1	1	
More-Way Packaging	ABS	4	2	-
		5	1	-

6.2.3 Warehouse Storing

More way packaging and
One Way Packaging
Max 3 Pallet layers
3rd layer with offset

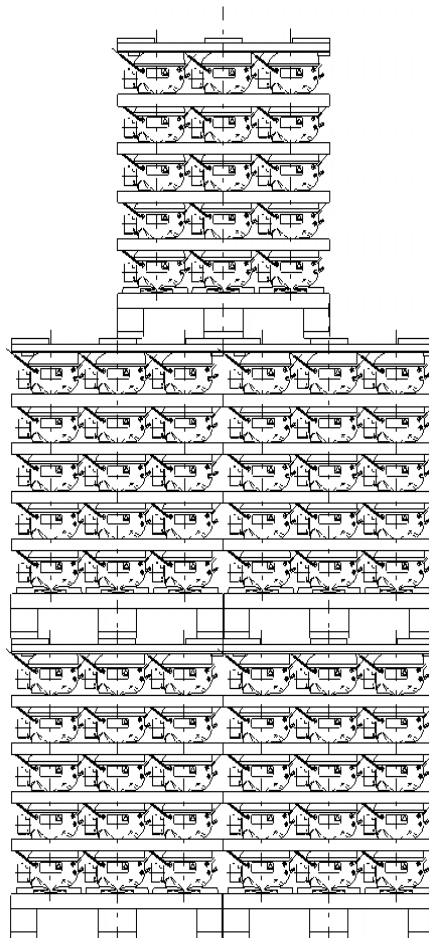

6.2.4 Recycling of compressors



Oil and gas must be recycled separately. Afterwards the compressor must be removed from the refrigerator and has to be given to a scrap metal recycling unit.

7 Electrical Components

7.1 Electronic Driver Assembly

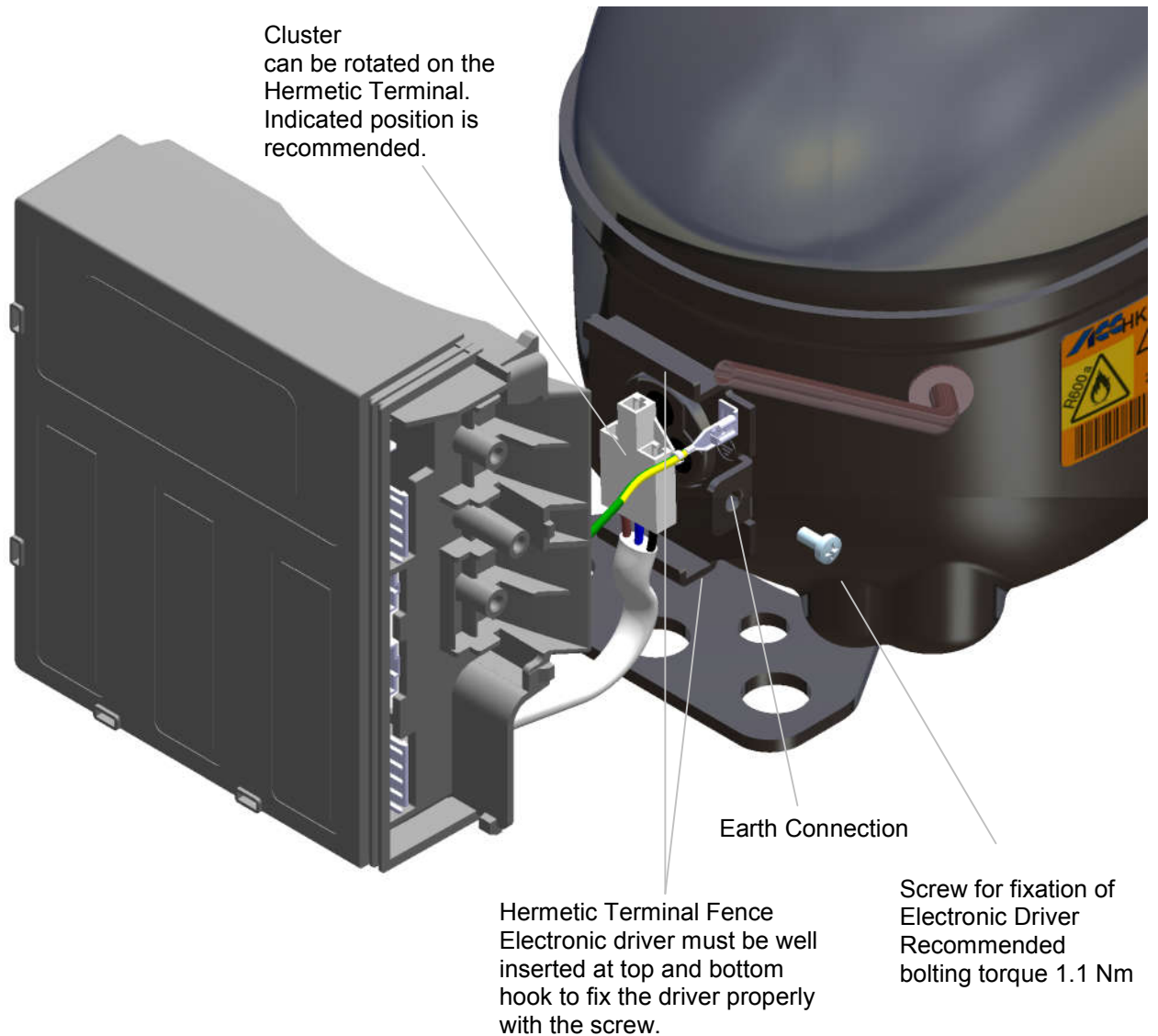

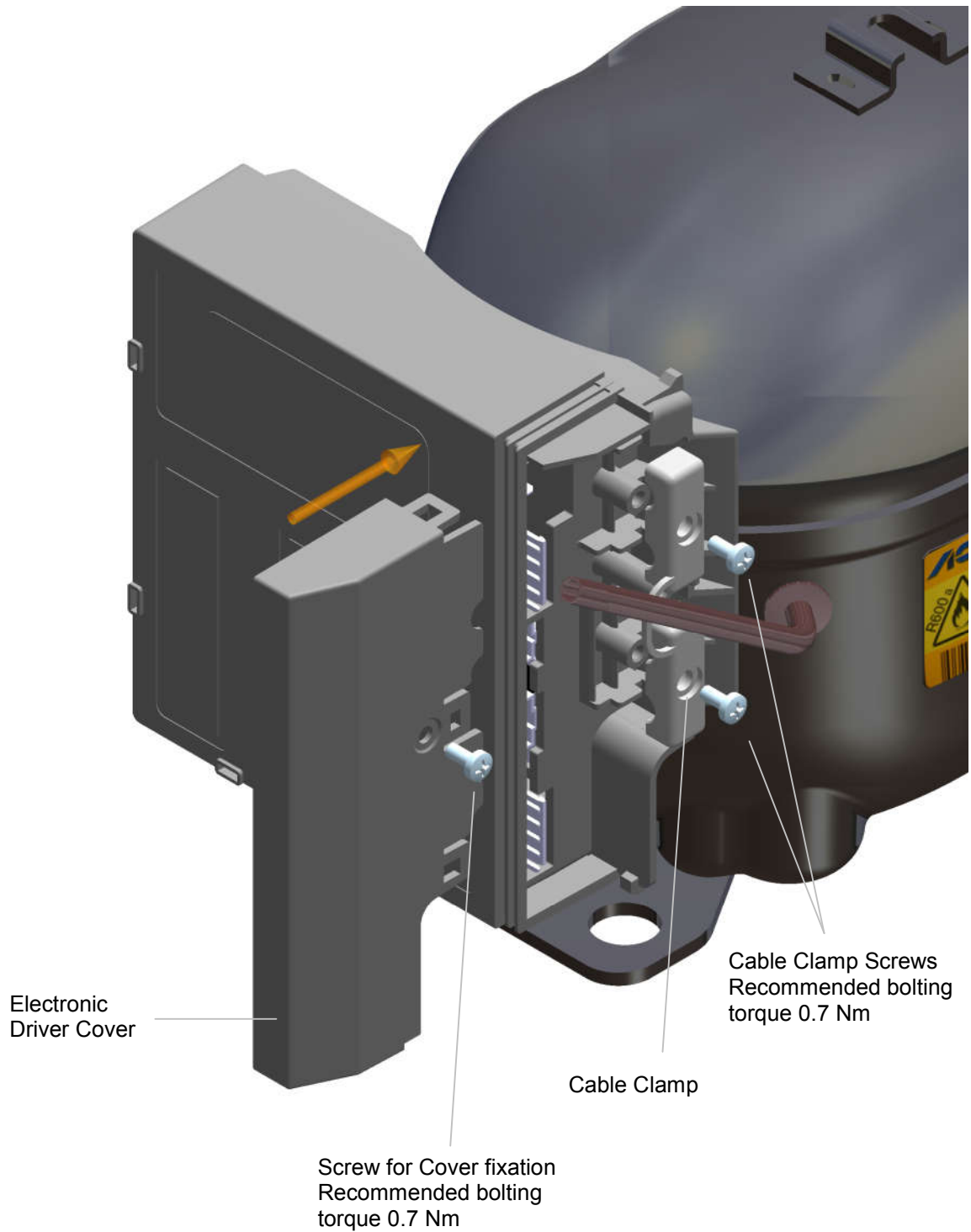

7.2 Dismounting of connector for frequency control

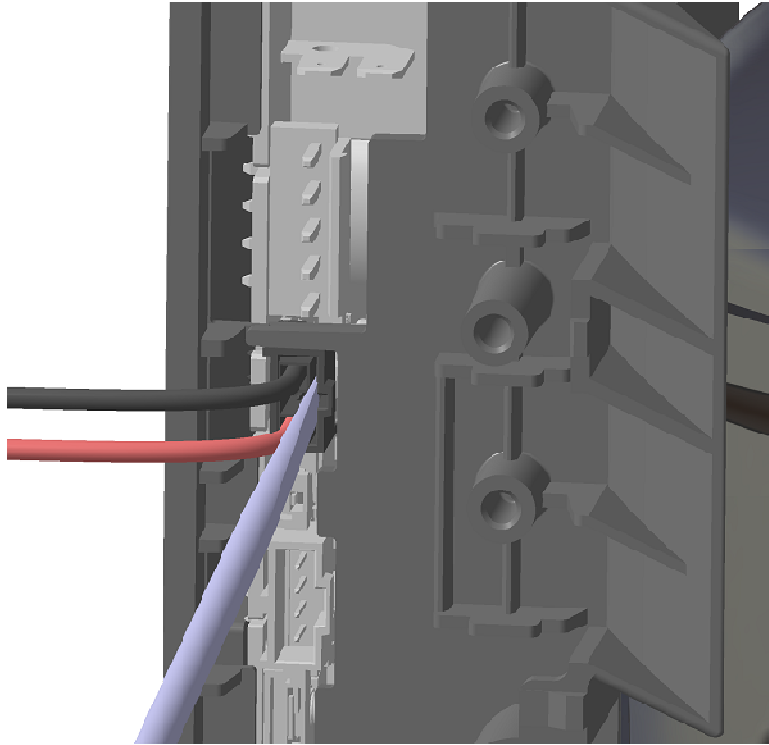

Lift the cover with screwdriver to unlock the hook for dismounting of connector.

8 Mounting Accessories

8.1 Standard

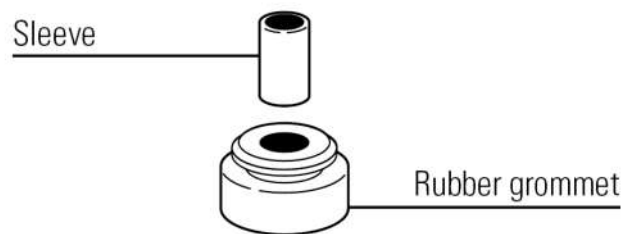

8.2 Optional

