

Product Data Sheet

HXK70AA

Revision 1

(Variant Code B)

1 Application

Application	Refrigerant	Expansion Device	Cooling Type
LBP	R600a	Capillary	Static

1.1 Application Conditions

Max. Ambient temp. ¹	[°C]	43
Max. Steady discharge temp. ²	[°C]	120
Max. Peak discharge temp. ^{2, 5}	[°C]	135
Max. Steady condensing temp. ³	[°C]	60
Max. Peak condensing temp. ^{3, 5}	[°C]	70
Max. Winding temp. ⁴	[°C]	130

¹...static

²...measured on discharge tube, 50 mm from the shell

³...measured in the middle of condenser

⁴...calculated out of the measured difference of resistance

⁵...max 5% of lifetime

Variant code according to Label; see General Product Documentation

2 Mechanical Data

Displacement	[cm ³]	6,6
Net Weight ¹	[kg]	8,4
Oil Type		mineral
Oil Charge	[ml]	165
Oil Viscosity	[cst]	5
Suction muffler		Semi direct
Free Gas Volume	[cm ³]	1550
Length L	[mm]	194,2
Width W	[mm]	151,5
Height H	[mm]	167

¹...Compressor without accessories

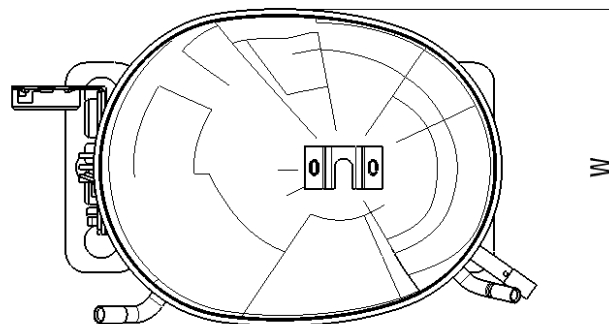
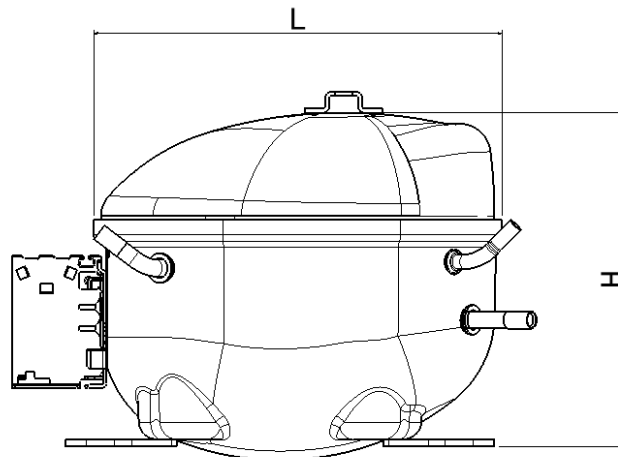

3 Electrical Data

Power supply	[V]	220 - 240
Voltage range¹	[V]	187 - 264
Frequency	[Hz]	50
Phase	[ph]	1
Motor type		RSCR
Locked rotor current @ steady state	[A]	2,4
Max. Locked rotor current / measured after 4 sec	[A]	7,5 / 3,1
Main wind. Resistance @ 25°C	[Ω]	32,4
Start wind. Resistance @ 25°C	[Ω]	24,1

¹...Operating and starting (starting condition @ +43°C windings temperature, 3,5 barA equalized pressure)

All data measured according to EN 60335

3.1 Electrical Component Data

Terminal board		ECC
Starting device	Code	K120
PTC	Type	A
Run Capacitor	[μF]	3 ; 4

3.2 Motor Protector

Motor Protector	BDG	Senbao
Type	AE 25 FJ x	B43 115 x
Code	F6	MW

4 Performance Data

4.1 Cooling Capacity, COP and Input Power

Performance Table Cooling Capacity @ ASHRAE / EN12900 (CECOMAF); 220V, 50Hz; [W]:

Evap. temp. [°C]		-35	-30	-25	-23,3	-20	-15	-10	
Condensing temp. @	ASHRAE [°C]	40	72,3	92,5	118,4	128,5	150,0	187,4	230,5
		45	67,1	88,0	114,6	125,0	147,0	185,2	229,0
		50	61,8	83,5	110,9	121,5	144,0	182,9	227,5
		55	56,6	79,0	107,1	118,0	141,0	180,6	226,0
		60	51,3	74,5	103,4	114,5	138,0	178,4	224,5
	EN12900 (CECOMAF) [°C]	C55	47,0	65,0	88,0	97,0	116,0	149,0	186,0

Performance Table COP with RC @ ASHRAE / EN12900 (CECOMAF); 220V, 50Hz; [W/W]:

Evap. temp. [°C]		-35	-30	-25	-23,3	-20	-15	-10	
Condensing temp. @	ASHRAE [°C]	40	1,53	1,82	2,11	2,20	2,40	2,69	2,98
		45	1,46	1,73	2,00	2,09	2,27	2,54	2,80
		50	1,40	1,64	1,89	1,98	2,14	2,39	2,63
		55	1,33	1,56	1,78	1,86	2,01	2,23	2,46
		60	1,27	1,47	1,68	1,75	1,88	2,08	2,29
	EN12900 (CECOMAF) [°C]	C55	1,11	1,28	1,47	1,53	1,66	1,84	2,02

Performance Table Input Power with RC @ ASHRAE / EN12900 (CECOMAF); 220V, 50Hz; [W]:

Evap. temp. [°C]		-35	-30	-25	-23,3	-20	-15	-10	
Condensing temp. @	ASHRAE [°C]	40	47,4	50,9	56,2	58,3	62,6	69,8	77,5
		45	45,9	50,9	57,4	59,8	64,9	73,0	81,7
		50	44,2	50,8	58,6	61,5	67,4	76,7	86,4
		55	42,4	50,7	60,0	63,4	70,2	80,8	91,9
		60	40,4	50,5	61,6	65,6	73,4	85,6	98,1
	EN12900 (CECOMAF) [°C]	C55	42,4	50,7	60,0	63,4	70,2	80,8	91,9

Test Conditions @ 220V/50Hz		ASHRAE	EN12900 (CECOMAF)
Evaporating temp.	[°C]	-23,3	-25
Condensing temp.	[°C]	55	55
Sub cooling temp.	[°C]	32	55
Suction temp.	[°C]	32	32
Ambient temp.	[°C]	32	32

Tolerance Range:

COP ± 5%
Cooling Capacity ± 5%

4.2 Rated current @ 55°C condensing temperature

Evaporating temperature	[°C]	-30	-23,3	-10
Rated current with RC	[A]	0,25	0,31	0,42

5 Reliability Tests

High Temperature CECOMAF GT4 – 002	passed
Wear CECOMAF GT4 – 003	passed
On – Off CECOMAF GT4 – 004	passed
Transport test ASTM D4728	passed