Product Data Sheet

HMK95AA K3

Revision 1

(Variant Code 3)

1 Application

Application	Refrigerant	Expansion Device	Cooling Type
LBP	R600a	Capillary	Static

1.1 Application Conditions

Max. Ambient temp.¹	[°C]	43
Max. Steady discharge temp.²	[°C]	120
Max. Peak discharge temp.^{2, 5}	[°C]	135
Max. Steady condensing temp.³	[°C]	60
Max. Peak condensing temp.^{3, 5}	[°C]	70
Max. Winding temp.⁴	[°C]	130

¹...static

²...measured on discharge tube, 50 mm from the shell

³...measured in the middle of condenser

⁴...calculated out of the measured difference of resistance

⁵...max 5% of lifetime

Variant code according to Label; see General Product Documentation

2 Mechanical Data

Displacement	[cm³]	9,6
Net Weight¹	[kg]	7,5
Oil Type		mineral
Oil Charge	[ml]	165
Oil Viscosity	[cst]	7
Suction muffler		Semi direct
Free Gas Volume	[cm³]	1500
Length L	[mm]	194,2
Width W	[mm]	151,5
Height H	[mm]	159

¹...Compressor without accessories

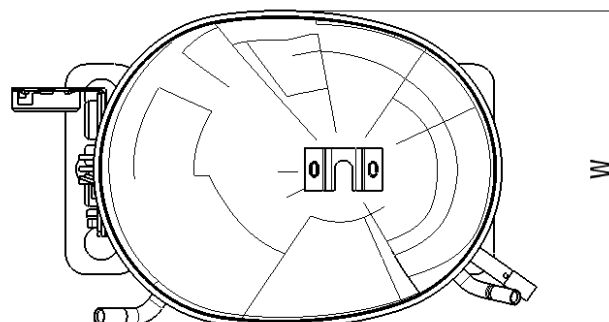
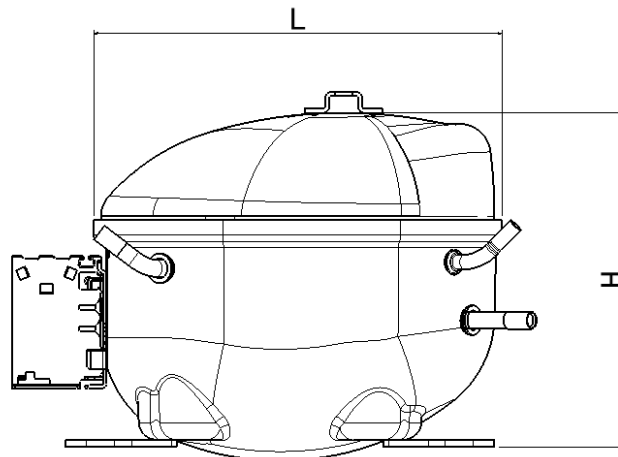

3 Electrical Data

Power supply	[V]	220 - 240
Voltage range ¹	[V]	187 - 264
Frequency	[Hz]	50
Phase	[ph]	1
Motor type		RSIR
Locked rotor current @ steady state	[A]	4,15
Max. Locked rotor current / measured after 4 sec	[A]	13,8 / 5,7
Main wind. Resistance @ 25°C	[Ω]	22,9
Start wind. Resistance @ 25°C	[Ω]	17,2

¹...Operating and starting (starting condition @ +43°C windings temperature, 3,5 barA equalized pressure)

All data measured according to EN 60335

3.1 Electrical Component Data

Terminal board		ECC
Starting device	Code	K100
PTC	Type	A
Run Capacitor	[μF]	-

3.2 Motor Protector

Motor Protector	BDG	Senbao
Type	AE 18 FU x	B64 120 x
Code	F5	MD

4 Performance Data

4.1 Cooling Capacity, COP and Input Power

Performance Table Cooling Capacity @ ASHRAE / EN12900 (CECOMAF); 220V, 50Hz; [W]:

Evap. temp. [°C]		-35	-30	-25	-23,3	-20	-15	-10	
Condensing temp. @	ASHRAE [°C]	40	80,3	117,5	160,2	176,0	208,5	262,2	321,6
		45	80,6	116,0	157,5	173,0	205,1	258,9	318,7
		50	80,9	114,5	154,8	170,0	201,8	255,5	315,9
		55	81,2	113,0	152,1	167,0	198,4	252,1	313,0
		60	81,5	111,5	149,3	164,0	195,1	248,7	310,1
	EN12900 (CECOMAF) [°C]	C55	67,0	93,0	125,0	138,0	163,0	207,0	257,0

Performance Table COP without RC @ ASHRAE / EN12900 (CECOMAF); 220V, 50Hz; [W/W]:

Evap. temp. [°C]		-35	-30	-25	-23,3	-20	-15	-10	
Condensing temp. @	ASHRAE [°C]	40	1,10	1,40	1,70	1,80	1,99	2,29	2,59
		45	1,08	1,35	1,62	1,71	1,89	2,16	2,42
		50	1,06	1,30	1,54	1,62	1,78	2,02	2,26
		55	1,04	1,25	1,46	1,53	1,67	1,89	2,10
		60	1,01	1,20	1,38	1,44	1,57	1,75	1,94
	EN12900 (CECOMAF) [°C]	C55	0,85	1,03	1,20	1,26	1,37	1,55	1,72

Performance Table Input Power without RC @ ASHRAE / EN12900 (CECOMAF); 220V, 50Hz; [W]:

Evap. temp. [°C]		-35	-30	-25	-23,3	-20	-15	-10	
Condensing temp. @	ASHRAE [°C]	40	72,7	83,9	94,4	97,9	104,5	114,5	124,3
		45	74,5	85,9	97,3	101,2	108,7	120,1	131,5
		50	76,5	88,1	100,5	104,8	113,3	126,4	139,7
		55	78,5	90,5	104,1	108,9	118,6	133,6	149,1
		60	80,6	93,2	108,1	113,5	124,5	142,0	160,2
	EN12900 (CECOMAF) [°C]	C55	78,5	90,5	104,1	108,9	118,6	133,6	149,1



HMK95AA K3

Product Data Sheet (Variant Code 3)

Test Conditions @ 220V/50Hz		ASHRAE	EN12900 (CECOMAF)
Evaporating temp.	[°C]	-23,3	-25
Condensing temp.	[°C]	55	55
Sub cooling temp.	[°C]	32	55
Suction temp.	[°C]	32	32
Ambient temp.	[°C]	32	32

Tolerance Range:

COP ± 5%
Cooling Capacity ± 5%

4.2 Rated current @ 55°C condensing temperature

Evaporating temperature	[°C]	-30	-23,3	-10
Rated current without RC	[A]	0,71	0,76	0,85

5 Reliability Tests

High Temperature CECOMAF GT4 – 002	passed
Wear CECOMAF GT4 – 003	passed
On – Off CECOMAF GT4 – 004	passed
Transport test ASTM D4728	passed